

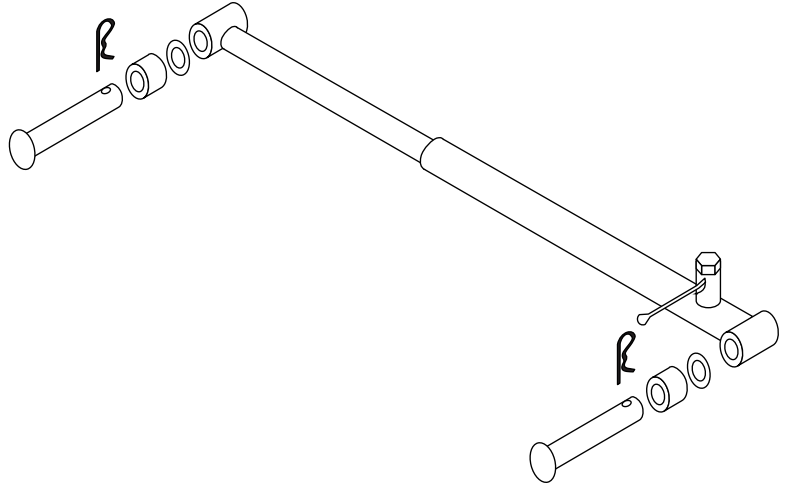

aby uniknąć pomyłek, proszę zawsze podawać typ brony, do której zamawiane są części  
um Verwirrung zu vermeiden, geben Sie bitte immer die Egge typ, die bestellten Teile  
in order to avoid mistakes, please provide harrow type when ordering spares  
werden pour éviter les malentendus merci de nous préciser à chaque fois le type de la herse pour laquelle vous commandez les pièces de rechange

00	01-02-0290
PL	blokada siłownika
D	blockade
GB	blockade
F	blocage
i	4m / 5m / 6m



00	01-02-0295
PL	blokada siłownika
D	blockade
GB	blockade
F	blocage
i	8m

01a	06-01-0005
PL	siłownik
D	zylinder
GB	piston
F	verin
i	4m / 5m / 6m

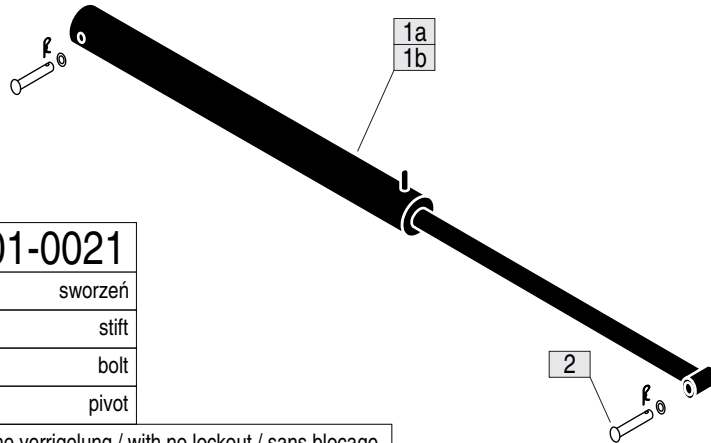

01b	06-01-0004
PL	siłownik
D	zylinder
GB	piston
F	verin
i	8m

02	08-01-0021
PL	sworzeń
D	stift
GB	bolt
F	pivot

i bez blokad / ohne verrigelung / with no lockout / sans blocage

00	0
PL	wąż
D	schlauch
GB	hose
F	tuyau
i	podaj długość / give lenght / Geben Sie die Länge / veuillez nous donner la longueur

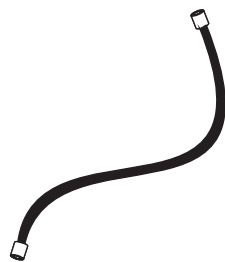

00	08-01-0020
PL	sworzeń dolny
D	unten stift
GB	lower bolt
F	pivot bas
i	4(4r)/5/6/8m

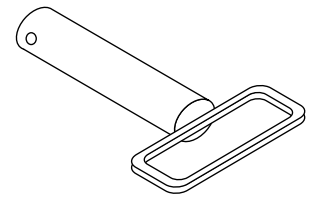

00	08-01-0017
PL	sworzeń górny
D	top stift
GB	top bolt
F	pivot superieur
i	2/3/4(3r)m

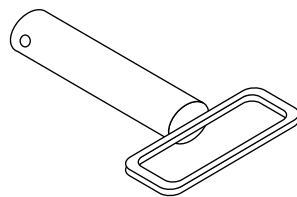

00	08-01-0019
PL	sworzeń górny
D	top stift
GB	top bolt
F	pivot superieur
i	4(4r)/5/6/8m

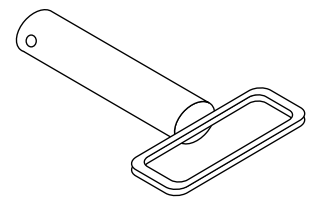



aby uniknąć pomyłek, proszę zawsze podawać typ brony, do której zamawiane są części  
um Verwirrung zu vermeiden, geben Sie bitte immer die Egge typ, die bestellten Teile  
in order to avoid mistakes, please provide harrow type when ordering spares  
werden pour éviter les malentendus merci de nous préciser à chaque fois le type de la herse pour laquelle vous commandez les pièces de rechange

00	0	ⓘ
PL	siatka	
D	netz	
GB	net	
F	tapis	

proszę podać typ brony / geben sie egge typ /  
please determine harrow type / Veuillez préciser le type de la herse

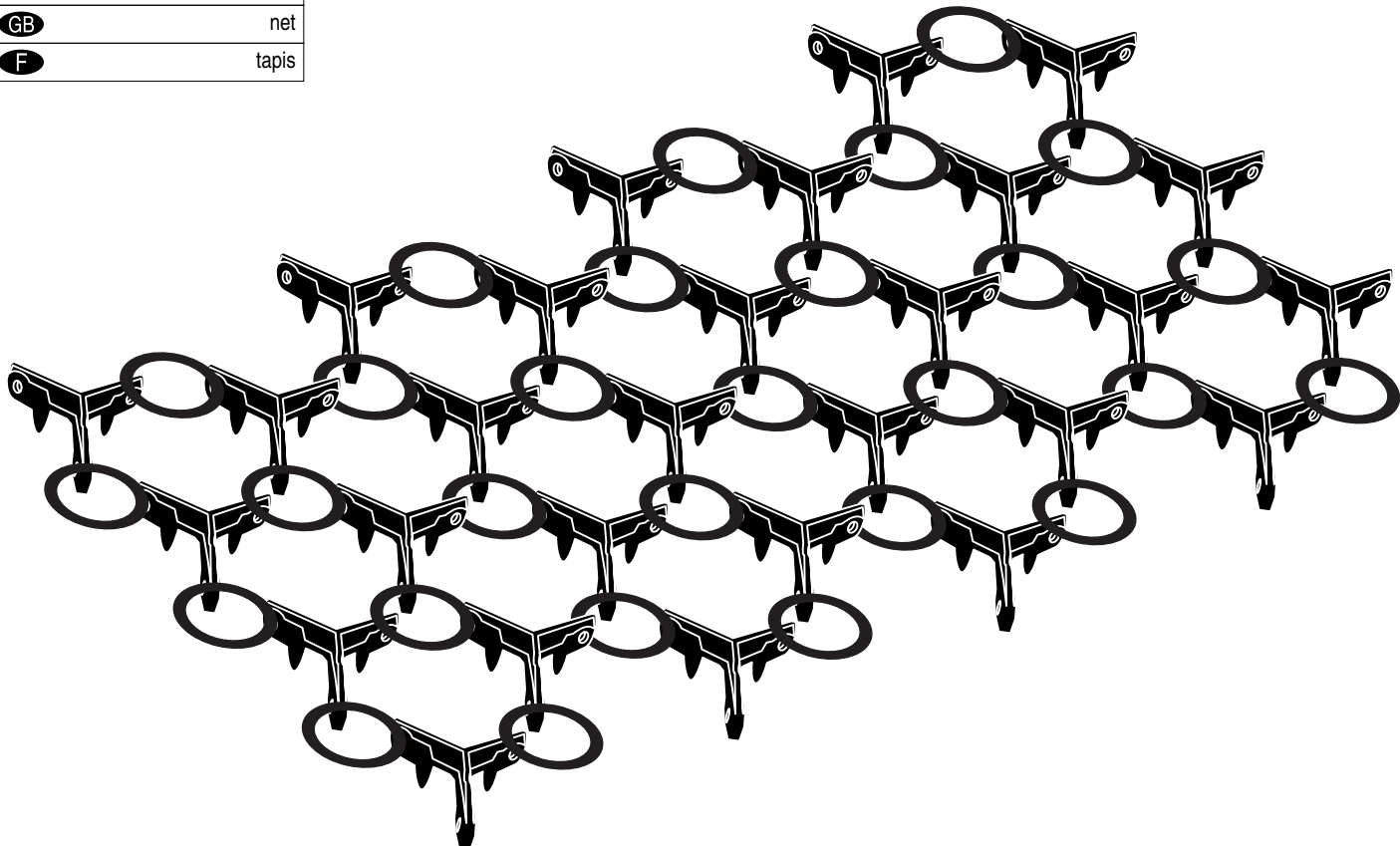

00	05-01-0010	
PL	odlew A	
D	guss A	
GB	drag A	
F	fonte A	
ⓘ	..	

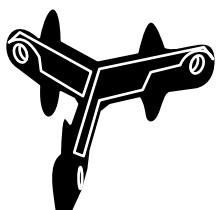

00	05-01-0008	
PL	odlew C	
D	guss C	
GB	drag C	
F	fonte C	
ⓘ	..	

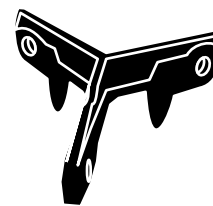

00	05-01-0007	
PL	odlew B	
D	guss B	
GB	drag B	
F	fonte B	
ⓘ	..	



00	0	
PL	kółko	
D	ring	
GB	ring	
F	anneau	
ⓘ	podaj średnicę / bitte durchmesser / provide diameter / veuillez nous donner le diametre	

